

C

Complements

Ethics, aesthetics & ideas.



MARTEX OFFICE

Complements collection.

RECEPTION	/ 2
SOFAS & SEATING	/ 20
MADIE & CABINETS	/ 58
STORAGES	/ 74
BOOKCASE, WOOD & STYLE	/ 82
BOOKCASE, MODULE & FUNCTION	/ 90
BOISERIE	/ 98

RECEPTION

SHELTER Design *Mario Mazzer*

SHELTER RECEPTION IS COMPOSED BY A SYSTEM OF MODULAR PANELS THAT, COMBINED AT EACH MARTEX DESK, ALLOWS COMPLETE FREEDOM OF COMPOSITION AND CONFIGURATION.

LA RECEPTION SHELTER È COMPOSTA DA UN SISTEMA DI PANNELLI MODULARI CHE, COMBINATI AD OGNI SCRIVANIA MARTEX, PERMETTONO LA TOTALE LIBERTÀ DI COMPOSIZIONE E CONFIGURAZIONE.



RECEIVE, COMMUNICATE, PROTECT.



\\ shelter \\\



**Thanks to its structure,
Shelter allows to personalize
every situation, creating
receptions and waiting areas
of high impact.**

**GRAZIE ALLA SUA STRUTTURA, SHELTER PERMETTE DI
PERSONALIZZARE OGNI SITUAZIONE, CREANDO SALE
RICEVIMENTO E ATTESA DI ALTA RAPPRESENTANZA.**



SOFAS & SEATING*

SOFTWARE, INATTESA,
ROMI, DUAL, FIFTY FIFTY

**A SOFAS AND SEATING
SYSTEM TO ASSURE
COMFORT, ERGONOMICS,
ABILITY TO RELAX
OR ACTIVE STANDBY.**

**UN SISTEMA DI DIVANI E SEDUTE CHE ASSICURANO COMFORT,
ERGONOMIA, POSSIBILITÀ DI RELAX O DI ATTESA ATTIVA.**



Thanks to its modern and elegant design, Software sofa can adjust to both waiting areas and great representation spaces.

GRAZIE AL SUO DESIGN MODERNO ED ELEGANTE, SOFTWARE È UN OGGETTO CHE SI ADATTA SIA A SITUAZIONI ATTESA CHE DI GRANDE RAPPRESENTANZA.



Prisma table.

Design *Mario Mazzer*

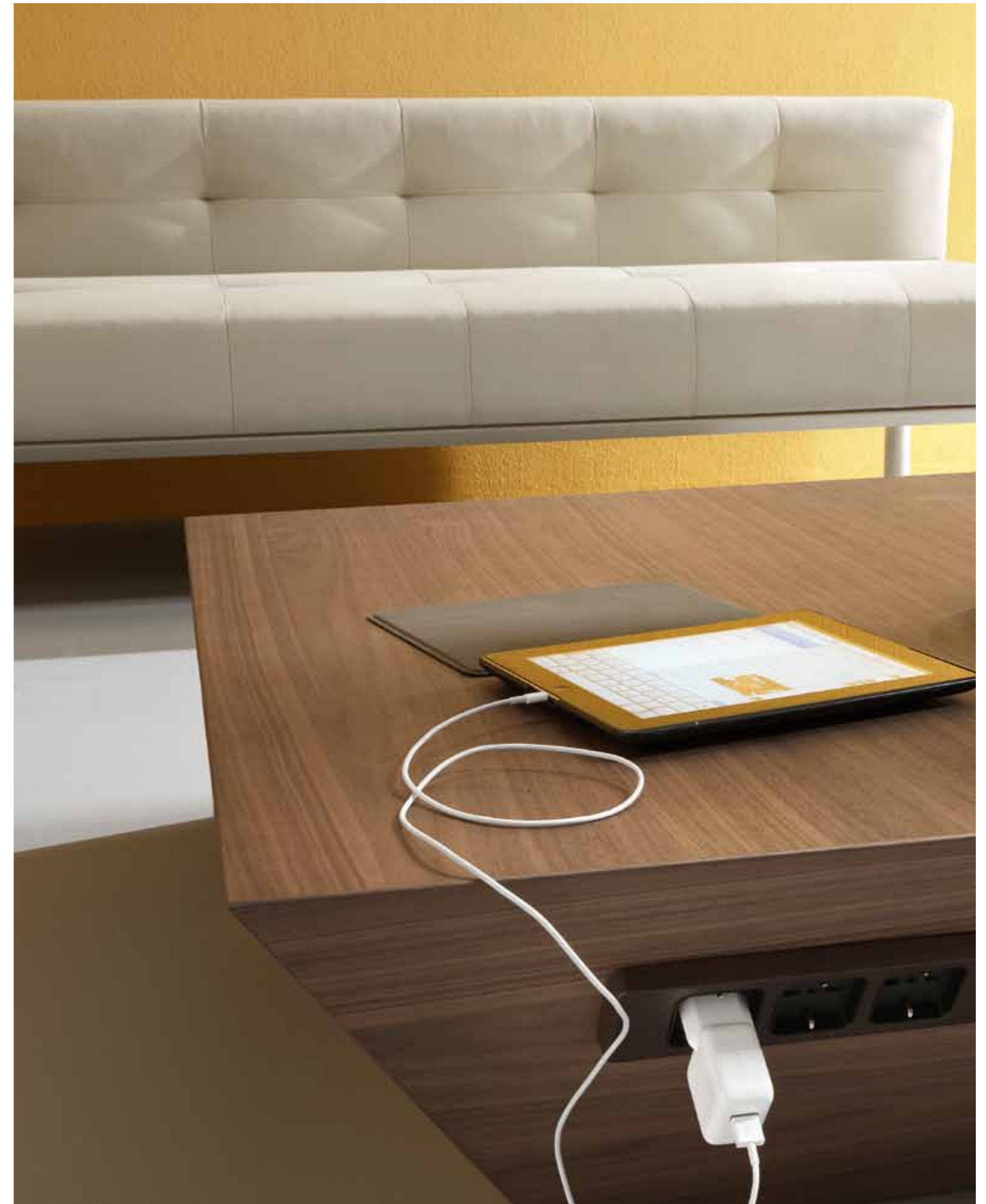

INATTESA

Design *Monica Graffeo*

The spirit of the collection is a mixture of informality and classic, reassuring and challenging at the same time; it's expressed both by individual elements or articulate and modular compositions where form and colour play a crucial role.

LO SPIRITO DI INATTESA È UN MISTO DI INFORMALITÀ E CLASSICITÀ, RASSICURANTE E STIMOLANTE AL TEMPO STESSO; SI ESPRIME SIA CON ELEMENTI SINGOLI CHE CON COMPOSIZIONI ARTICOLATE E MODULARI, DOVE FORMA E COLORI GIOCANO UN RUOLO DETERMINANTE.





INATTESA COLLECTION.



//////////////////// inattesa //////////////////////////////////////



The quilt and the back are totally removable and made of technic fabric intensive use resistant.

LA TRAPUNTA E LO SCHIENALE SONO TOTALMENTE SFODERABILI E REALIZZATI IN UN MATERIALE TECNICO RESISTENTE AD UN USO INTENSIVO.



LOUNGE, WAITING, WORKING.





Communication areas in the office contribute to wellness and productivity of the people.

ALL'INTERNO DELL'UFFICIO LE AREE DI COMUNICAZIONE E RELAZIONE CONTRIBUISCONO AL BENESSERE E ALLA PRODUTTIVITÀ DELLE PERSONE CHE LAVORANO.



Martex offers furniture solutions to equip functional project areas where meetings can take place, interfacing with required hardware to make presentations and video/audio conferencing.



MARTEX PROPONE SOLUZIONI D'ARREDO PER ATTREZZARE PROJECT AREAS DOVE È POSSIBILE EFFETTUARE BREVI MEETING, INTERFACCIANDOSI CON L'HARDWARE NECESSARIO A PRESENTAZIONI E VIDEO/AUDIO CONFERENZE.



ROMI

Design C R&S Martex

The new Romi stools allow creating informal work areas or comfortable coffee break corners so to create pleasant zones dedicated to socialize.

I NUOVI SGABELLI ROMI PERMETTONO DI CREARE DELLE INFORMALI AREE LAVORO O DEI CONFORTEVOLI ANGOLI PER LA PAUSA CAFFÈ; NELL'UFFICIO SI CREANO COSÌ PIACEVOLI ZONE DEDICATE ALLE RELAZIONI SOCIALI DELL'AZIENDA.



*** In leather or fabric coating,
Romi is available in 14
different colors.**

**IN ECOPELLE O IN TESSUTO, ROMI È DISPONIBILE IN 14
COLORI DIVERSI.**



DUAL

Design *Mario Mazzer*

**Dual is comfortable
and perfect around the
meeting table.**

**DUAL È CONFORTEVOLE E PERFETTA ATTORNO
AD UN TAVOLO RIUNIONE.**



Its duality, tub chair or high back, in boardrooms allows finding everyone's best posture.

NELLE SALE CONFERENZA, LA SUA DUALITÀ, POZZETTO O SCHIENALE ALTO, CONSENTE A CIASCUNO DI TROVARE LA PROPRIA POSTURA IDEALE.





DUAL MODE.

1* MOBILITY MOBILITÀ

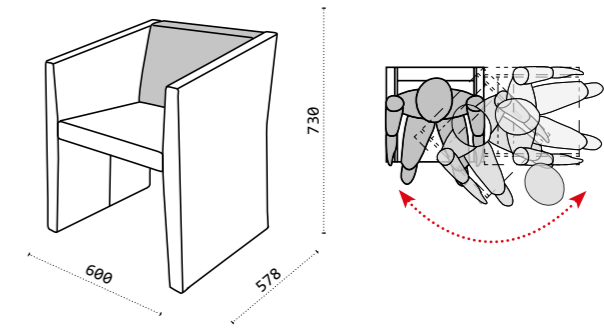

2* EASY ENTRY AND EXIT ENTRATA E USCITA FACILITATA

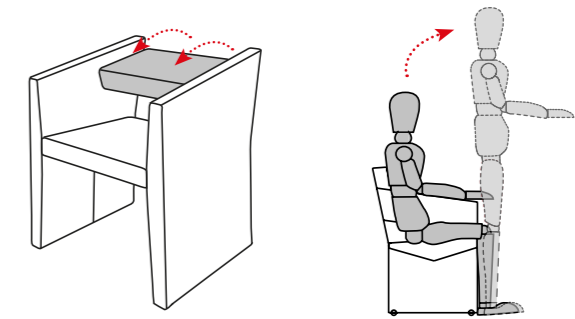

3* MOBILITY OF THE LOWER LIMBS MOBILITÀ DEGLI ARTI INFERIORI

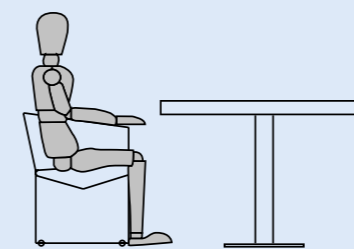
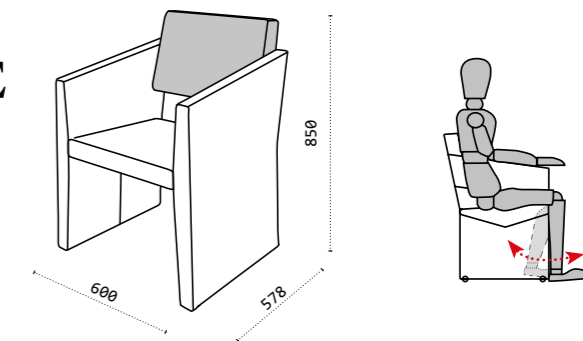

FORMAL SITTING
SEDUTA FORMALE

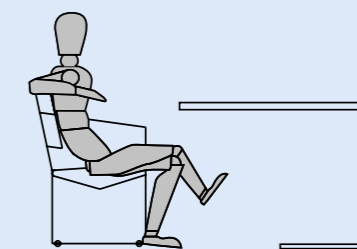

INFORMAL SITTING
SEDUTA INFORMALE



FIFTY FIFTY

Design Azzolini Tinuper

Fifty Fifty, a flexible system, available in two dimensions, one or two seats, is a clean cut 50's design ideal in articulated graphical compositions.

DISPONIBILE IN DUE DIMENSIONI, A UN POSTO E A DUE POSTI, CON SCHIENALE ALTO E CON SCHIENALE BASSO, FIFTY FIFTY SI PROPONE CON DIVERSE VESTI E MATERIALI CHE RICHIAMANO ALLA MENTE EMOZIONI E SEGNI TIPICI DEGLI ANNI '50.





Elegant, soft and cosy, Fifty Fifty sofas can make any environment they live exclusive and comfortable.

ELEGANTI, MORBIDE, AVVOLGENTI, LE SEDUTE E I DIVANI FIFTY FIFTY SANNO RENDERE ESCLUSIVO ED ACCOGLIENTE OGNI AMBIENTE CHE ABITANO.



Strong personality.



MADIE & CABINETS

**MARTEX SIDEBOARDS
AND CABINETS,
AVAILABLE IN DIFFERENT
FINISHES, ALLOW
A PERFECT MATCHING
WITH OTHER MODELS.**

**LE MADIE E I CONTENITORI MARTEX, DISPONIBILI IN VARIE
FINITURE, PERMETTONO UN PERFETTO ACCOSTAMENTO
ALLE ALTRE PROPOSTE ARREDATIVE.**





MADIA

Design Mario Mazzer

**Elegant cupboard perfect
for office closet and high
representation rooms.**

ELEGANTE CONTENITORE DIREZIONALE IDEALE
PER ARREDARE ANCHE SALE DI ALTA RAPPRESENTANZA.

PULL OUT SLIDING DOORS MADIA

Design *R&D Martex*

Pull-out sliding doors allow full spaces' exploitation clearing them of the door's size.

LE ANTE COMPLANARI PERMETTONO LO SFRUTTAMENTO TOTALE DEI VANI LIBERANDOLI COMPLETAMENTE DALL'INGOMBRO DELL'ANTA.





TOTEM

Design *Mario Mazzer*

Totem bookcase shows up like this: unconventional in its formal expression but of great aesthetical/functional impact and much more than this. Its geometrical rhythm creates effective alternation of form.

LA LIBRERIA TOTEM SI PRESENTA COSÌ: NON CONVENZIONALE NELL'ESPRESSIONE FORMALE, MA DI GRANDE IMPATTO ESTETICO E FUNZIONALE E NON SOLO. IL SUO RITMO GEOMETRICO CREA EFFICACI ALTERNANZE DI FORMA.



CABINETS

The office complements furnish without occupying much of space, fit easily into any environment, personalize the spaces.

I COMPLEMENTI ARREDANO SENZA OCCUPARE MOLTO SPAZIO, SI INSERISCONO FACILMENTE IN OGNI AMBIENTE, PERSONALIZZANO GLI SPAZI.





\\ hanging cabinet Design Mario Mazzer \\\



Zazà, in alternation from the traditional doors, is used on cabinets or storages when giving a lightness idea and functionality to the furniture is required.

ZAZÀ, IN ALTERNATIVA ALLE TRADIZIONALI ANTE, VIENE APPLICATA SU MOBILI APPESI O CONTENITORI QUANDO SI DESIDERA DARE UN'IDEA DI LEGGEREZZA E FUNZIONALITÀ AGLI ARREDI.



STORAGES

ZAZÀ, GALAXY

MARTEX PROPOSE A SERIES OF STORAGES THAT CAN BE EQUIPPED WITH SHELVES TO STORE DOCUMENTS OR TO CONTAIN A FRIDGE, TRAYS FOR GLASSES AND BOTTLES OR A COAT HANGER.

MARTEX PROPONE UNA SERIE DI ARMADI CHE INTERNAMENTE POSSONO ESSERE ATTREZZATI PER RIPORRE DOCUMENTI, OPPURE PER CELARE IL FRIGO BAR, VASSOI PORTA BICCHIERI E PORTA BOTTIGLIE O UNA BARRA APPENDI ABITI.







\\ galaxy storages \\\



Contain & organize.



BOOKCASE, WOOD & STYLE

BLOCK

Design R&D Martex



**FLEXIBLE AND HIGH
CAPACITY STORAGE
SYSTEM. AVAILABLE
IN OPEN VERSION, WITH
GLASS DOORS AND
LACQUERED BACK-PANEL
OR WITH CLEAR GLASS
DOORS AND BACK-PANEL.**

**SISTEMA DI CONTENIMENTO FLESSIBILE AD ALTA CAPACITÀ
CONTENITIVA E DISPONIBILE IN VERSIONE A GIORNO, CON
ANTE IN CRISTALLO E SCHIENA LACCATA OPPURE CON
ANTE E SCHIENA IN VETRO TRASPARENTE.**



A high-end bookcase for a high representation office.

UNA LIBRERIA DI ALTO LIVELLO PER UN UFFICIO DI ALTA
RAPPRESENTANZA.



LIGHT CROSSES THE SPACE.





Clear elegance.



BOOKCASE, MODULE & FUNCTION

CUBIK

Design R&D Martex



**SINGLE MODULES,
JOINABLE, CAN GENERATE
A FUNCTIONAL STORAGE
SYSTEM THAT CAN BE
PERSONALIZED IN FINISH
AND COLOURS.**

**MODULI SINGOLI, TRA LORO ACCOSTABILI, PERMETTONO DI
GENERARE UN SISTEMA DI CONTENIMENTO FUNZIONALE E
PERSONALIZZABILE NELLE FINITURE E NEI COLORI.**





**Lightness, containment
and great luminosity.**

LEGGEREZZA, CONTENIMENTO E GRANDE LUMINOSITÀ.





**STORE,
ORGANIZE,
SEE.**



BOISERIE

Design *Mario Mazzer*

**MARTEX BOISERIE IS
CHARACTERIZED BY
MAXIMUM FLEXIBILITY
IN APPLICATIONS AND
DESIGN OF SPACES
OR SINGLE WALLS TO
CREATE A PROTECTIVE
AND WELCOMING
ENVIRONMENT.**

**LA BOISERIE MARTEX SI CARATTERIZZA PER LA MASSIMA
FLESSIBILITÀ NELLE APPLICAZIONI E NELLA PROGETTAZIONE
DI AMBIENTI O SINGOLE PARETI PER CREARE UN AMBIENTE
PROTETTIVO E ACCOGLIENTE.**







Modular system.



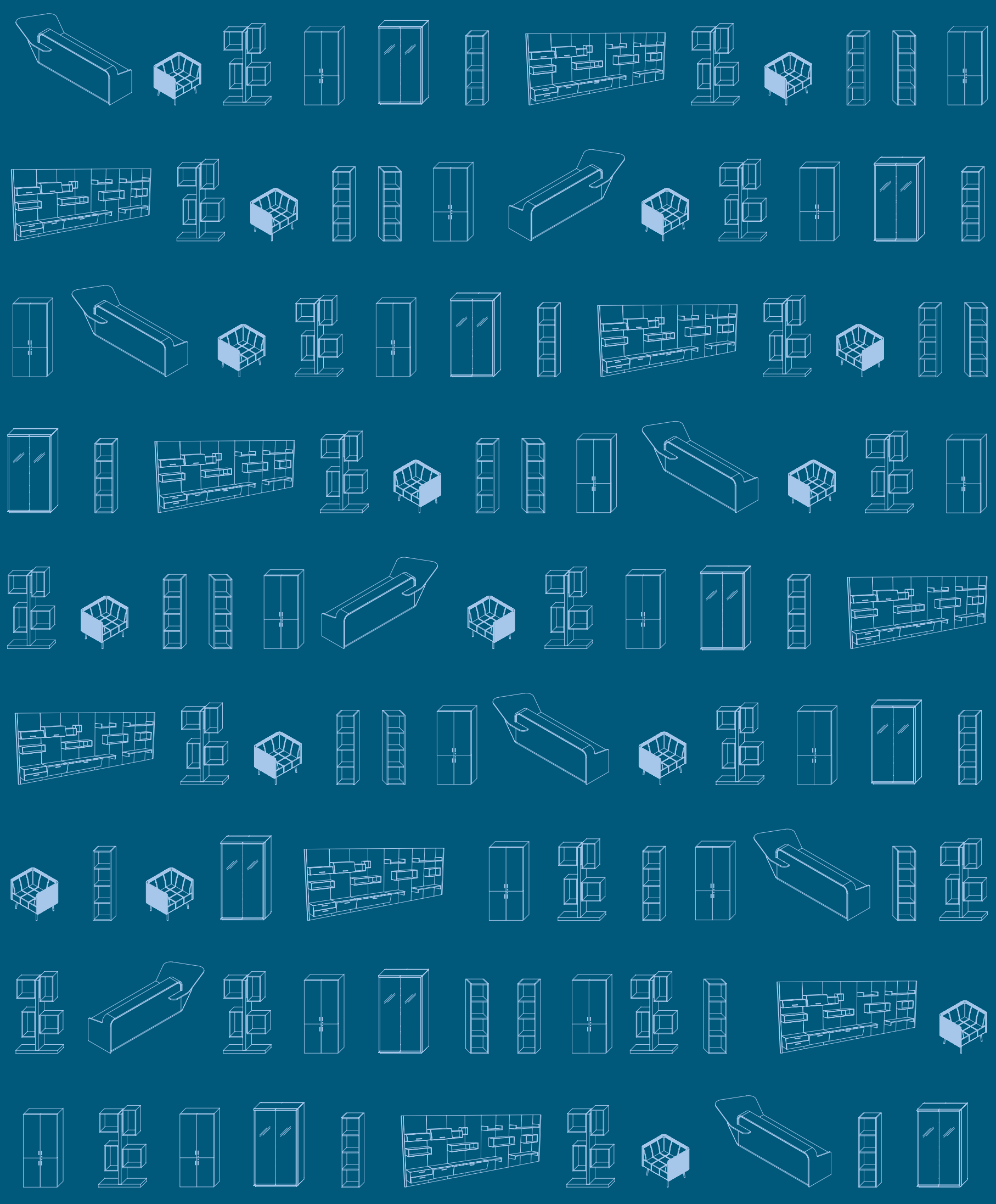

Overview

RECEPTION

Shelter / 107

SOFAS & SEATING

Software / 108

Inattesa / 109

Romi / 110

Dual / 110

Fifty Fifty / 110

COFFEE TABLES / 111

MADIE & CABINETS / 112

STORAGES / 114

BOOKCASE, WOOD & STYLE / 114

BOOKCASE, MODULE & FUNCTION / 115

LEARNING & TEACHING / 115

BOISERIE

Free componibility / 116

Wire management / 118



RECEPTION

Shelter



Reception panel
Pannello reception

W/L 800-900-1000 H 1100



Reception panel with 1 corner W 320 mm
Pannello reception con 1 angolo L 320 mm

W/L 660-760-860 H 1100



Reception panel with 2 corners W 320 mm
Pannello reception con 2 angoli L 320 mm

W/L 520-620-720 H 1100



SOFAS & SEATING

Software



Ottoman
Ottomano

W/L 1200-1400-1600-1800-2000
D/P 820 H 430



Sofa with back
Divano con schienale

W/L 1600-1800-2000
D/P 820 H 700



Sofa with back and armrests
Divano con schienale e braccioli

W/L 1600-1800-2000
D/P 820 H 700



Sofa D.1000 mm with cushions
Divano P.1000 mm con cuscini

W/L 1600-1800-2000
D/P 1000 H 700



Armrest
Bracciolo

W/L 750 D/P 400 H 120

SOFAS & SEATING

Inattesa



1 or 2 seater pouf with feet
Pouf con piedini 1 o 2 posti

W/L 750-1580 D/P 630 H 410



1 or 2 seater floor pouf
Pouf a terra 1 o 2 posti

W/L 750-1580 D/P 630 H 410



1 or 2 seater floor pouf with low back
Pouf a terra 1 o 2 posti con schienale basso

W/L 780-1610 D/P 690 H 740



2 seater floor pouf with low back
Pouf a terra 2 posti con schienale basso

W/L 1650 D/P 690 H 740



2 seater floor pouf with high back
Pouf a terra 2 posti con schienale alto

W/L 1610 D/P 690 H 1350



1 seater floor pouf with low or high back
Pouf a terra 1 posto con schienale basso o alto

W/L 820-1650 D/P 690 H 740-1350



2 seater floor pouf with low or high back
Pouf a terra 2 posti con schienale basso o alto

W/L 1650 D/P 690 H 740-1350



Armchair with low or high back
Poltrona con schienale basso o alto

W/L 820 D/P 690 H 740-1350



Sofa with low or high back
Divano con schienale basso o alto

W/L 1650 D/P 690 H 740-1350



SOFAS & SEATING

Romi _____ Dual _____



Stool
Sgabello

W/L 490 D/P 530 H 1070



Armchair
Poltrona

W/L 600 D/P 578 H 730/850

Fifty Fifty _____



1 seater pouf
Pouf 1 posto

W/L 830 D/P 565 H 420



2 seater pouf
Pouf 2 posti

W/L 1370 D/P 565 H 420



Armchair
Poltrona

W/L 1050 D/P 680 H 840



Sofa
Divanetto

W/L 1590 D/P 680 H 840



High backed Sofa
Divanetto schienale alto

W/L 1590 D/P 680 H 1275

COFFEE TABLES



High or low table
Tavolino alto o basso

W/L 500-930 D/P 500-800 H 430-580



Oval waiting area table
Tavolo attesa ovale

W/L 1000 D/P 600 H 410



Round waiting area table
Tavolo attesa tondo

W/L 380 D/P 380 H 520



High table
Tavolino alto

W/L 600 D/P 600 H 1100



Th.70 mm top table
Tavolo attesa con piano sp.70 mm

W/L 755-1200 D/P 755-1200 H 430



Anywhere waiting area table
Tavolo attesa Anyware

W/L 600-800-1000-1200-1400
D/P 600-800-1000-1200-1400 H 400



Han waiting area table
Tavolo attesa Han

W/L 600 D/P 600 H 405



Han waiting area table
Tavolo attesa Han

W/L 1200 D/P 600 H 405



Walnut Prisma table
Tavolo attesa Prisma in noce

W/L 1000 D/P 1000 H 318

MADIE & CABINETS

Madie



Madie with wooden handle
Madie con maniglia legno

W/L 1200 D/P 448 H 1500



Madie with lacquered handle
Madie con maniglia laccata

W/L 1200 D/P 448 H 1500



Pull out sliding door cabinet
Madie complanare

W/L 2228 D/P 560 H 864



Totem
Totem

W/L 1000 D/P 400 H 1860



Cubical hanging element
Pensile Cubo

W/L 480 D/P 380 H 480

MADIE & CABINETS

Cabinets



Cabinet
Mobiletto

W/L 1030 D/P 454 H 530



Cabinet with pillar legs
Credenza con piantane

W/L 2030 D/P 454 H 755



Cabinet with sled basement
Credenza con basamento slitta

W/L 2030 D/P 454 H 770



Drop door cabinet with feet
Base a ribalta con piedi

W/L 2004 D/P 500 H 700



Drop door cabinet
Contenitore con anta a ribalta

W/L 2004 D/P 500 H 1185



Service unit on castors
Mobile di servizio su ruote

W/L 1454 D/P 448 H 580



Service unit on feet
Mobile di servizio su piedi

W/L 1454 D/P 448 H 750



Hanging cabinet with Zazà doors
Contenitore appeso con anta Zazà

W/L 1600-1800-2000 D/P 400 H 420



Hanging cabinet with sliding doors
Contenitore appeso con ante scorrevoli

W/L 1600-1800-2000 D/P 400 H 420

STORAGES

Galaxy



Galaxy - 1 module
Galaxy - 1 modulo

W/L 450 D/P 454
H 768-1152-1536-1920-2340



Galaxy - 1 module
Galaxy - 1 modulo

W/L 900 D/P 454
H 768-1152-1536-1920-2340

Zazà



Zazà Storage - 1 module
Zazà Storage - 1 modulo

W/L min 900 max 2700 D/P 454
H 768-1152-1536-1920-2340

BOOKCASE, WOOD&STYLE

Block



Block bookcase with wooden back
Libreria Block con schiena legno

W/L 1200 D/P 450 H 1500



Glass doors Block cupboard
Vetrina Block con ante vetro

W/L 1200 D/P 450 H 1500



Glass doors and back Block cupboard
Vetrina Block con ante e schiena vetro

W/L 1200 D/P 450 H 1500

BOOKCASE, MODULE&FUNCTION

Cubik



Cubik open unit bookcase - 1 module
Libreria a giorno Cubik - 1 modulo

W/L 600-1200 D/P 382 H 1020-1500-1980
TV module - W/L 1800 H 1000



Cubik bookcase with glass doors - 1 module
Libreria con ante vetro Cubik - 1 modulo

W/L 600-1200 D/P 382 H 1020-1500-1980

LEARNING&TEACHING



Hot desk
Hot desk

W/L 900-1800-2700
D/P 675 H 1600



Internet point
Internet Point

W/L 900-1800-2700
D/P 600 H 1070



Multimedia support on castors
Totem multimediale su ruote

W/L 1200 D/P 500 H 2000

BOISERIE **Free componibility**

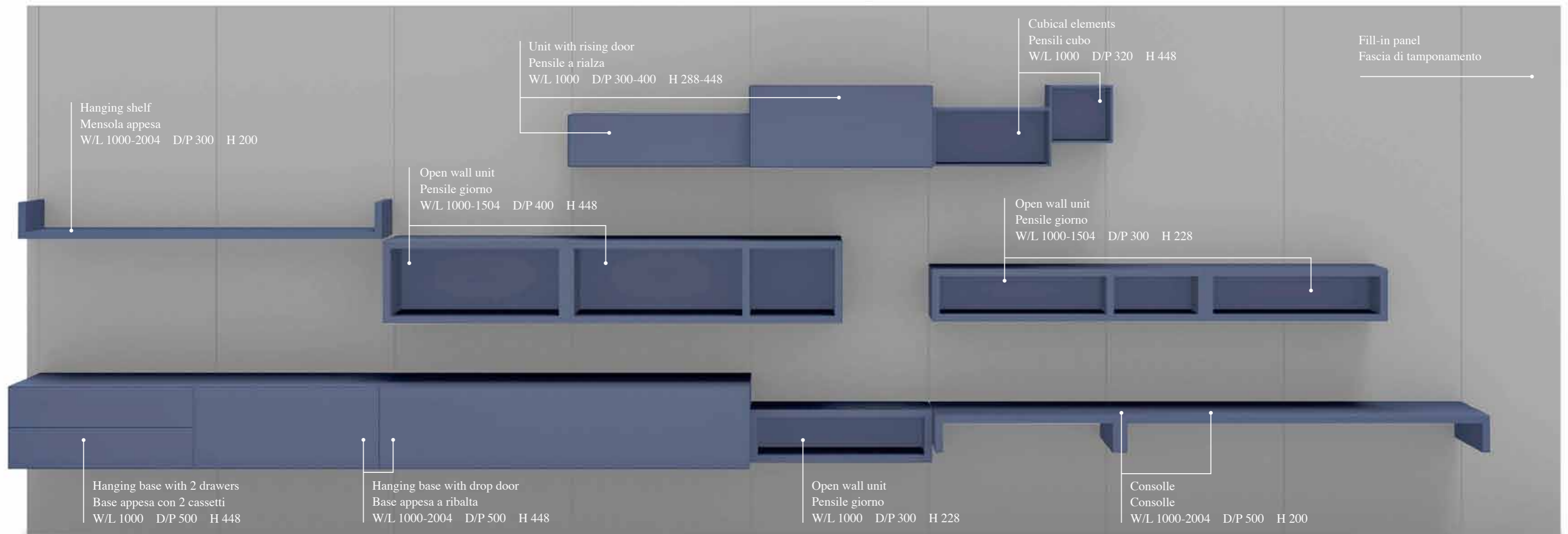

BOISERIE Wire management

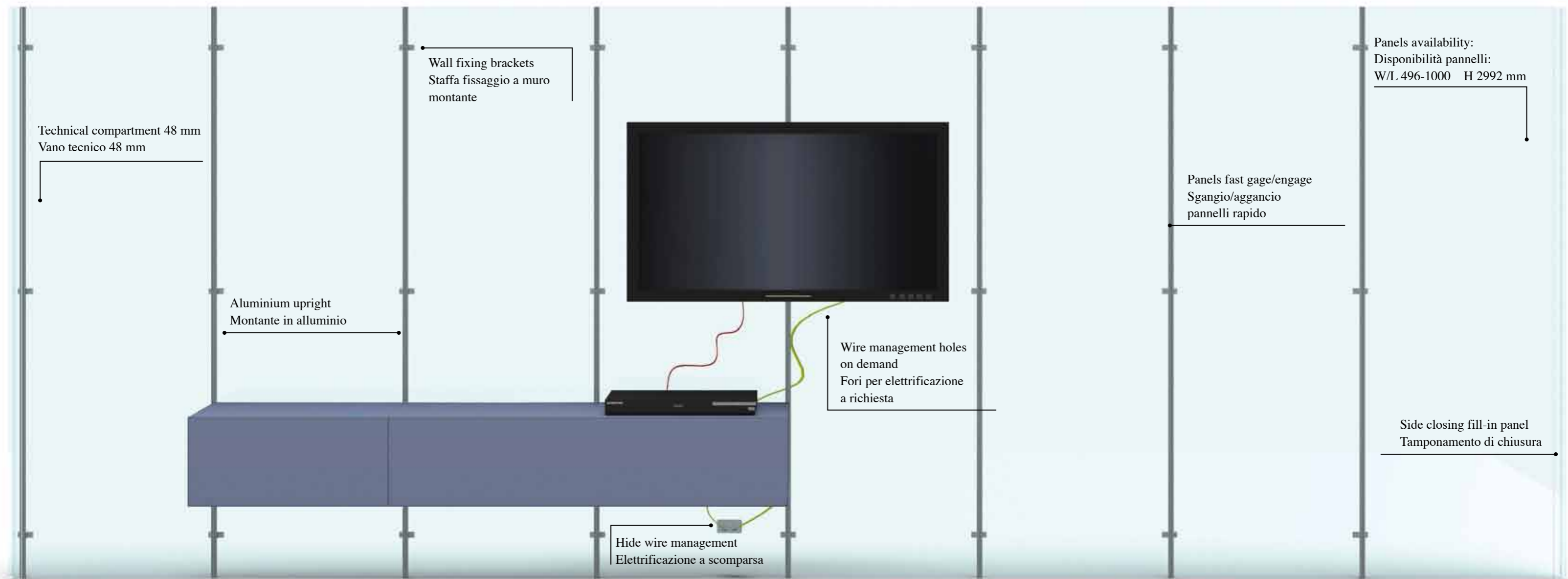

CREDITS

agency _ Consilia

photo _ Gabriotti Fotografi

art buyer _ Carla Bernardis

print _ Sincromia

photolitho _ Lucegroup



martex.it

Via Sagree, 19 - Prata di Pordenone (PN) ITALY · Tel. +39 0434 602310 · Fax +39 0434 602319 · info@martex.it