



PANTAGRUEL

This round picnic table has been aptly named Pantagruel, after Gargantua's son in the literary masterpieces of Rabelais.

There are striking likenesses between the two tables, but a few differences too, for example in their features and the atmosphere they project. The round tabletop of the Pantagruel is fitted with a Lazy Susan, a central revolving tray. The legs are available with a powder coating. The seats are no longer height-adjustable, as they were with the Gargantua. The overall impression is still recognisably sturdy, but the look is just that little bit more elegant, which will make Pantagruel more popular with fans of a more refined aesthetic.



GARGANTUA AND HIS SON PANTAGRUEL

In 1994, Dirk Wynants found the name of his very first creation in the work of François Rabelais. The main characters, the giant Gargantua and his son Pantagruel are Rabelais' most famous literary creations. Even today, the terms Rabelaisian and gargantuan are often spontaneously linked with an overabundance of food and drink, ...

[Read more](#)

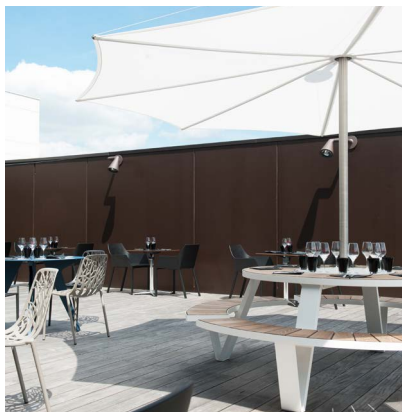

AU COMPTOIR VENITIEN, RENNES, FR

This restaurant in Rennes, France, uses Pantagruel tables in combination with our Inumbra parasol for a cosy dinner.

[Check out the pics](#)

CHECK ALL THE DETAILS

Choose galvanised steel legs for extreme durability, or powder coated steel legs for a more refined look. In combination with our Inumbra or Inumbria parasol it's an awesome eye-catching set up!



[Discover more of this collection](#)

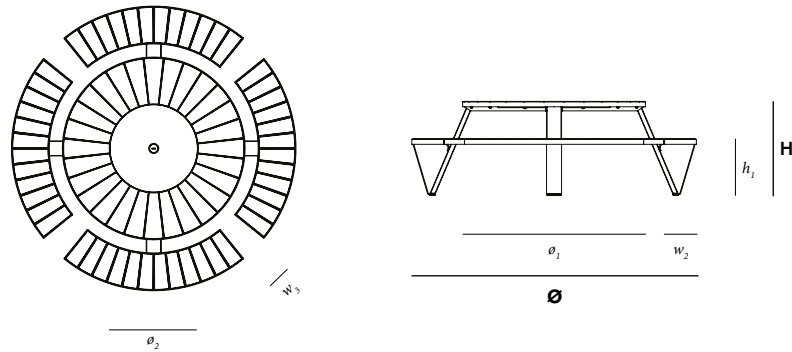

Dimensions (mm)	Ø	H	Ø₁	Ø₂	l₁	w₁	h₁
Pantagruel	2275	747	1460	700	302	226	447

PANTAGRUEL WITH OPTIONAL BACK RESTS

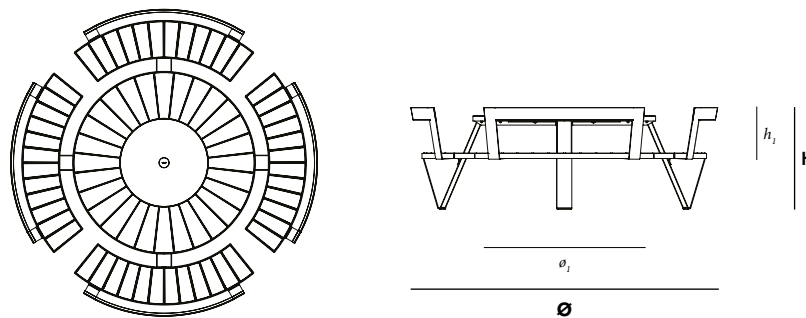

Dimensions (mm)	Ø	H	h₁	l₁
Back rest	2452	812	413	1283

[Download technical sheet – 3d drawings – 2d drawings](#)

MOODS

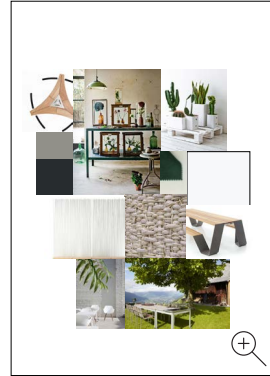
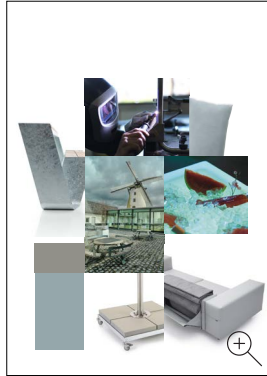

Contact information?

Sanne Figoureux | +32 57 346020 | sanne@extremis.be