



m. zone

Get in the zone.



Future offices need to provide employees with differentiated, versatile work environments which offer supportive settings for a variety of activities. Rigid spatial structures are disappearing. Space needs to be designed around the tasks that are to be performed. "Activity Based Working" is the order of the day. With *m.zone*, Wiesner-Hager has developed a mould-breaking interior design concept for offices which is perfectly suited to the organisation of agile businesses. *m.zone* consists of individual elements such as

room dividers, modular and standalone furniture pieces, which can be combined flexibly to create new working environments to suit client's individual ideas and needs. As it is highly versatile, *m.zone* is ideal for a wide range of application areas within the office architecture: Open plan offices, collaborative spaces and lounges, as well as reception and waiting areas.

Design: LUCY.D



work.

Inspired by the traditional bureau, these furniture elements can be combined to create single workstations for focused, temporary working. Workstations can be screened off to a greater or lesser degree according to the level of privacy required.

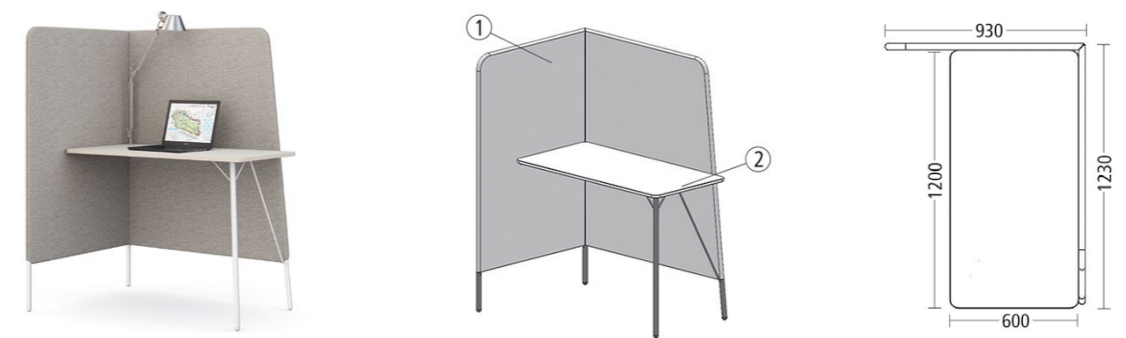

m.zone single left – worktop height 900 mm

consists of:

- ① 1 screen
- ② 1 worktop

Without illustration: *m.zone single right* – worktop height 900 mm

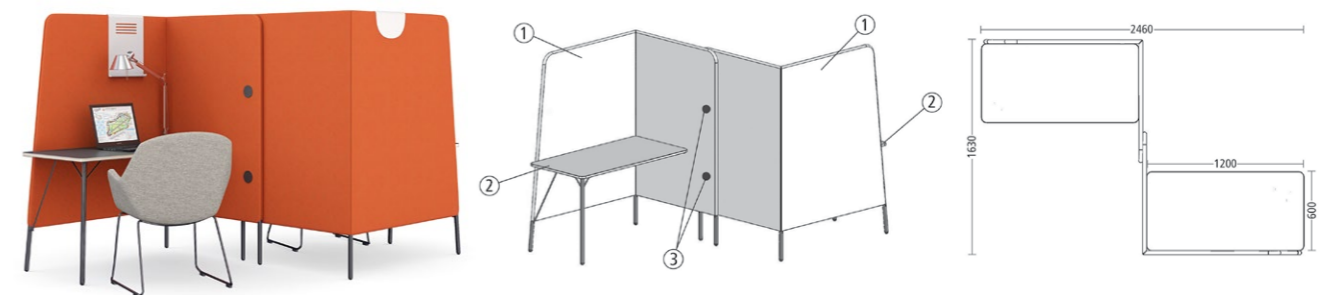

m.zone double – worktop height 740 mm

consists of:

- ① 2 screens
- ② 2 worktops
- ③ 2 connectors

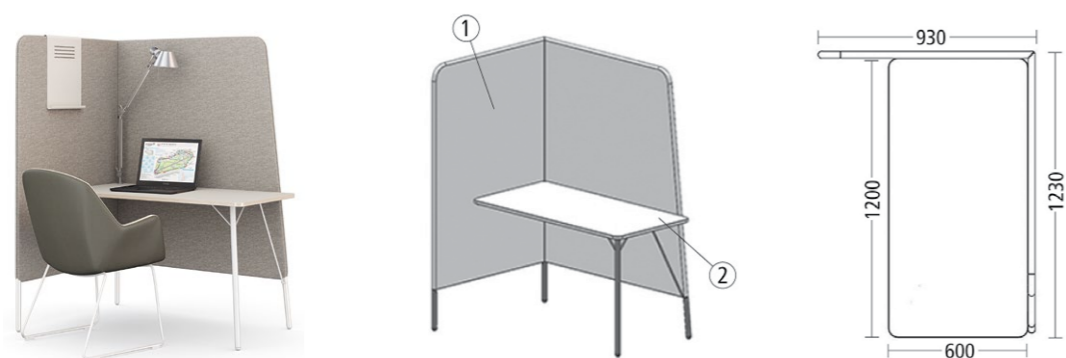

m.zone single left – worktop height 740 mm

consists of:

- ① 1 screen
- ② 1 worktop

Without illustration: *m.zone single right* – worktop height 740 mm

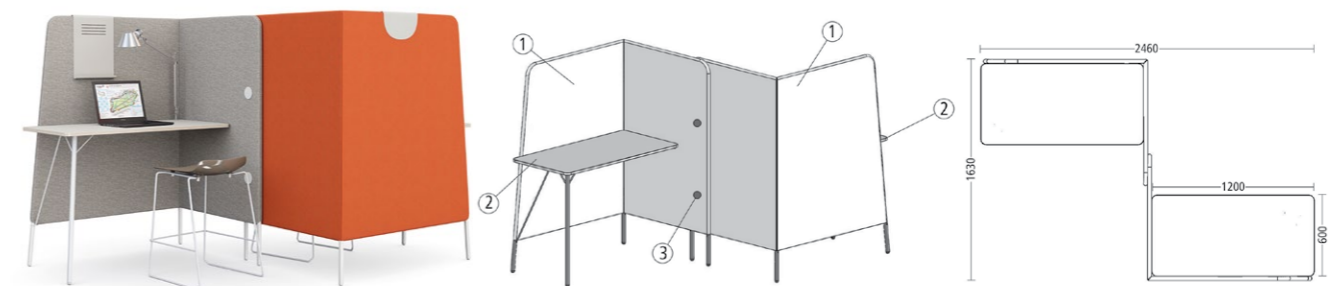

m.zone double – worktop height 900 mm

consists of:

- ① 2 screens
- ② 2 worktops
- ③ 2 connectors

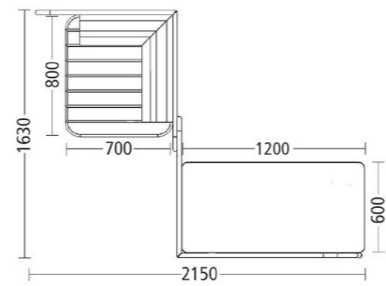
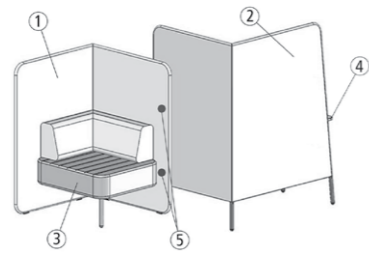

m.zone double mixed – worktop height 740 mm

consists of:

- ① 1 screen
- ② 1 screen
- ③ 1 armchair, seat height 460
- ④ 1 worktop
- ⑤ 2 connectors

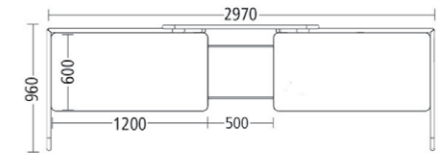
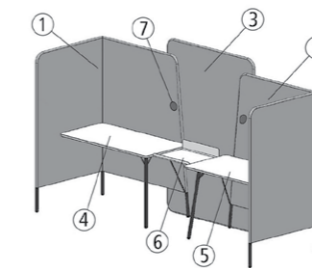

m.zone team – worktop height 740 mm

consists of:

- ① 1 screen
- ② 1 screen
- ③ 1 screen
- ④ 1 worktop
- ⑤ 1 worktop
- ⑥ 1 connecting shelf
- ⑦ 4 connectors

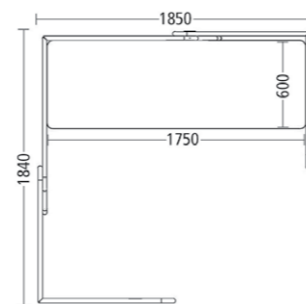
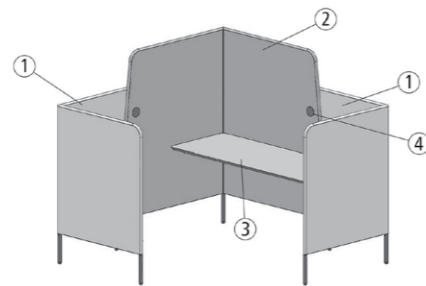

m.zone cell left – worktop height 740 mm

consists of:

- ① 2 screens
- ② 1 screen
- ③ 1 worktop
- ④ 4 connectors

Without illustration: **m.zone cell right** – worktop height 740 mm

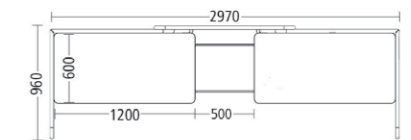
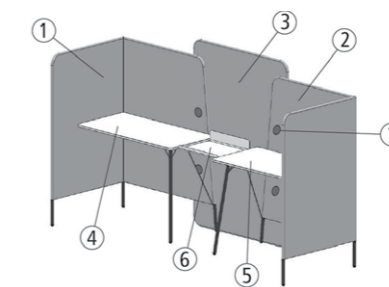

m.zone team – worktop height 900 mm

consists of:

- ① 1 screen
- ② 1 screen
- ③ 1 screen
- ④ 1 worktop
- ⑤ 1 worktop
- ⑥ 1 connecting shelf
- ⑦ 4 connectors

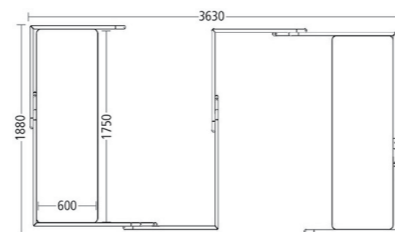
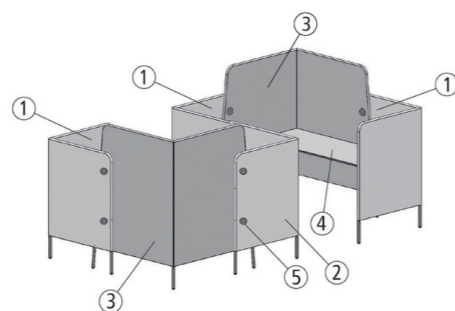

m.zone cell double – worktop height 740 mm

consists of:

- ① 3 screens
- ② 1 screen
- ③ 2 screens
- ④ 2 worktops
- ⑤ 10 connectors

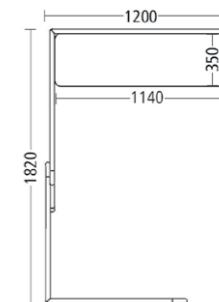
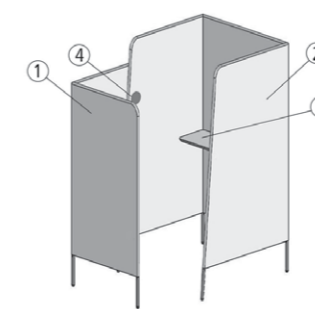

m.zone phone box left – worktop height 900 mm

consists of:

- ① 1 screen
- ② 1 screen
- ③ 1 worktop
- ④ 2 connectors

Without illustration: **m.zone phone box right** – worktop height 900 mm



Zones for collaboration and communication. Flexibly connected room dividers form the basis for various types of applications such as (team) meetings, informal discussions or workshops to generate ideas. Furniture modules may be chosen and configured flexibly to suit the particular application.

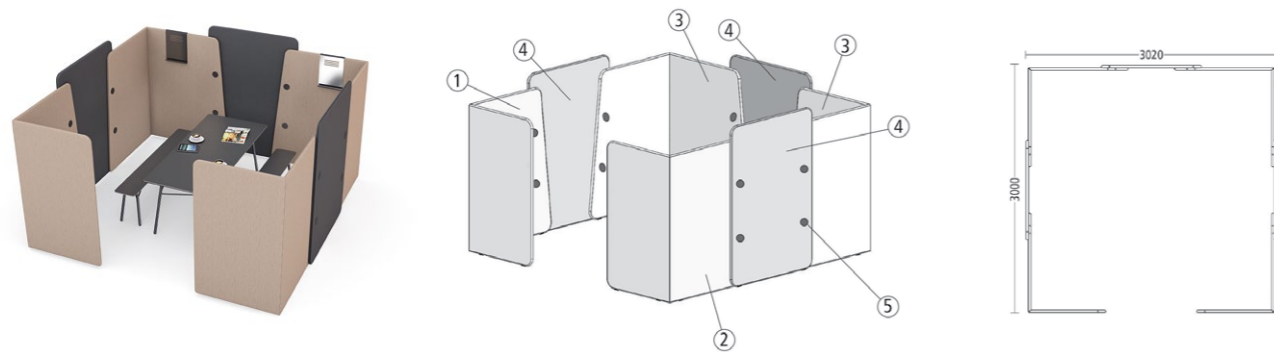

m.zone meeting box

- consists of:
- ① 1 screen
 - ② 1 screen
 - ③ 2 screens
 - ④ 3 screens
 - ⑤ 12 connectors

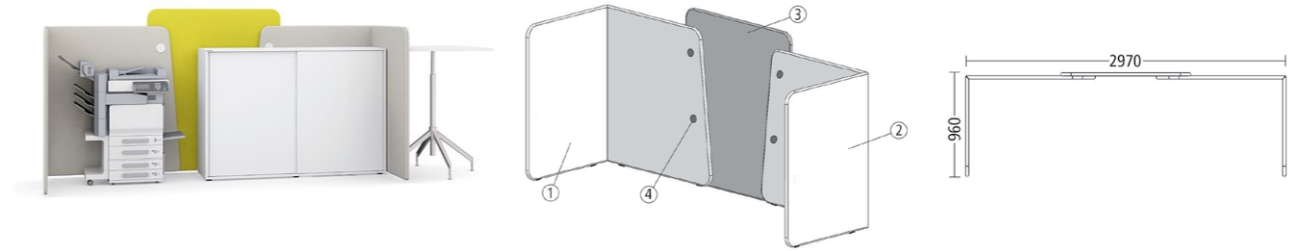

m.zone shield A

- consists of:
- ① 1 screen
 - ② 1 screen
 - ③ 1 screen
 - ④ 4 connectors

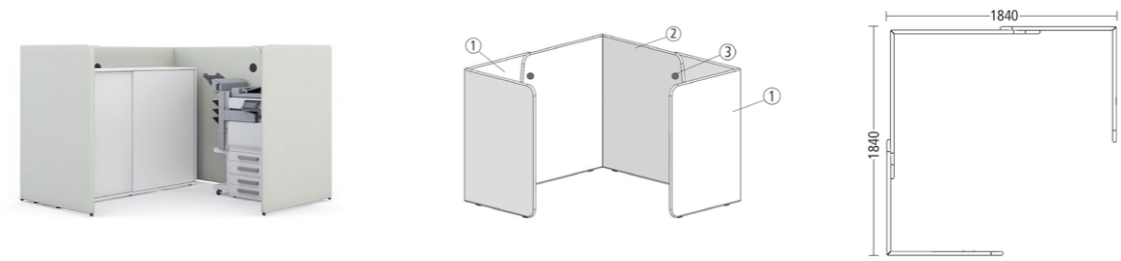

m.zone shield B

- consists of:
- ① 2 screens
 - ② 1 screen
 - ③ 4 connectors



m.zone talk

2344-816
800/800
height 740

2345-816
800/800
height 900



m.zone pub

2342-836 Table **pub**
800/1800
height 740

2343-990 Bench **pub**
270/1680
seat height 450

relax.



Quiet zones and spaces for relaxation and reflection. Comfortable seating elements and screening room dividers create a relaxed atmosphere for tea breaks, informal discussions and social interaction.

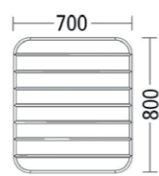

m.zone ottoman

2324-104
seat height 460

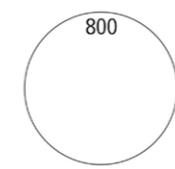

m.zone coffee table

2346-116
height 550

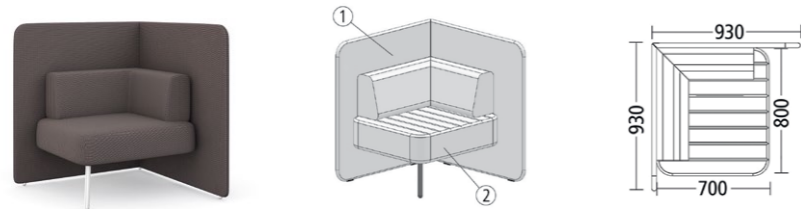

m.zone armchair left – screen height 1000 mm

consists of:

- ① 1 screen
- ② 1 armchair, seat height 460

Without illustration: **m.zone armchair right** – screen height 1000 mm

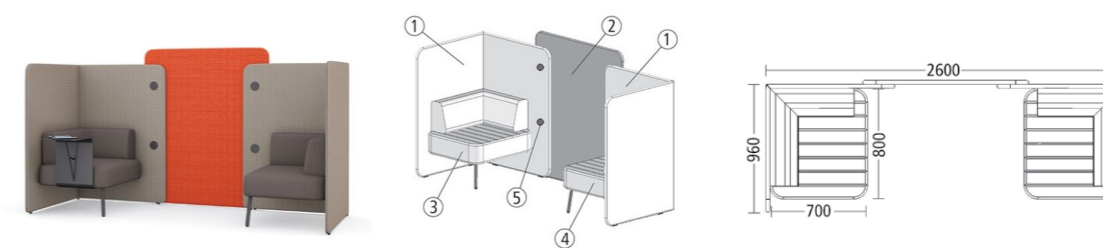

m.zone twin seat – screen height 1300 mm

consists of:

- ① 2 screens
- ② 1 screen
- ③ 1 armchair, seat height 460
- ④ 1 armchair, seat height 460
- ⑤ 4 connectors

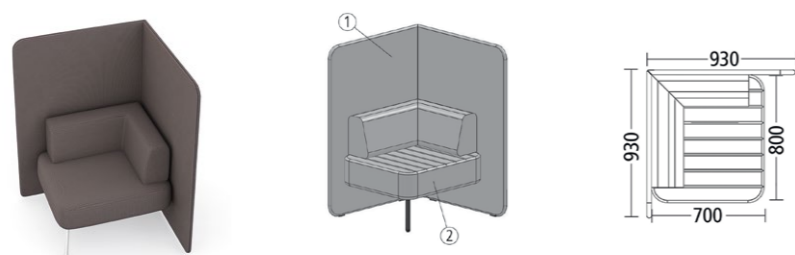

m.zone armchair left – screen height 1300 mm

consists of:

- ① 1 screen
- ② 1 armchair, seat height 460

Without illustration: **m.zone armchair right** – screen height 1300 mm

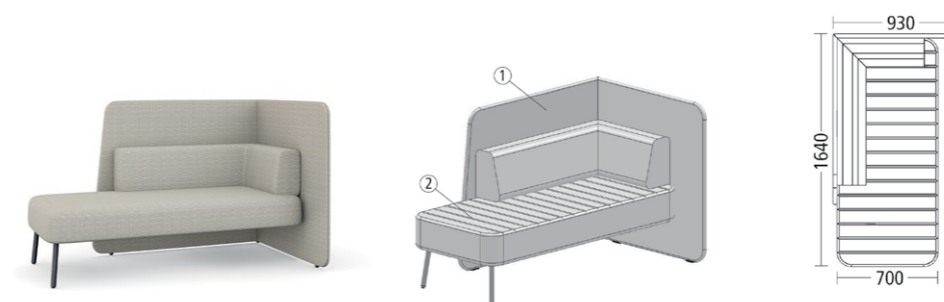

m.zone couch left – screen height 1000 mm

consists of:

- ① 1 screen
- ② 1 couch, seat height 460

Without illustration: **m.zone couch right** – screen height 1000 mm

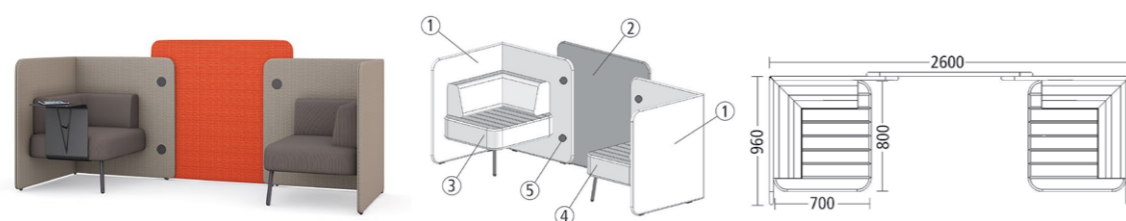

m.zone twin seat – screen height 1000 mm

besteht aus:

- ① 2 screens
- ② 1 screen
- ③ 1 armchair, seat height 460
- ④ 1 armchair, seat height 460
- ⑤ 4 connectors

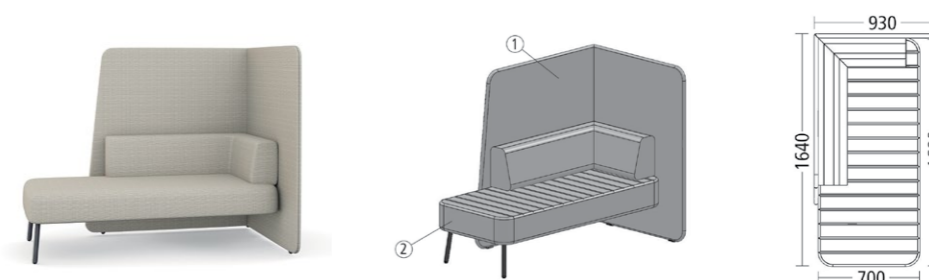

m.zone couch left – screen height 1300 mm

consists of:

- ① 1 screen
- ② 1 couch, seat height 460

Without illustration: **m.zone couch right** – screen height 1300 mm

Accessories.



2335-000 Table board – single
suitable for armchairs and couches



2334-000 Table board right – double
suitable for couches



2336-000 Table board left – double
suitable for couches



2340-000 Connector
suitable for screens



2337-000 Connecting shelf
suitable for **m.zone team**



2338-000 Memoboard
suitable for screens



2339-970 Suspended shelf
180 x 700 mm
suitable for screens



2339-971 Suspended shelf
180 x 950 mm
suitable for screens



Standard models:

Screens:

Screen 2300 to 2303, 2315:
Fabric-covered panel, plastic glides.

Screens 2307 to 2311:
Fabric-covered panel, foot tubular steel, plastic glides.
Metal surfaces powder-coated acc. to WH collection.

Important note:
Fabrics from the following collections are not suitable for upholstery: leather *paloma*.

Connector 2340:
Connector element steel for screens, Ø 80 mm. Metal surface powder-coated acc. to WH collection.

Worktops:

Choice of laminate (MFC) top with seamless, moisture-resistant laser edge (ABS edge) or HPL top with bevelled edge (Multiplex), oiled. Worktop 2328 to 2331 with support tubular steel, plastic glides. Metal surface powdercoated acc. to WH collection.

Armchair, couch and ottoman:

Seat and back fully upholstered, seat upholstery with top-stitched seams, foot tubular steel, plastic glides. Metal surface powdercoated acc. to WH collection.

Table and bench *pub*, *table talk*, *coffee table*:

Top laminate (HPL) with bevelled edge (Multiplex), oiled. Frame tubular steel, tables adjustable plastic glides, bench plastic

glides. Metal surfaces powder-coated acc. to WH collection.

Table board, connecting shelf and memo board:
Steel, metal surface powdercoated acc. to WH collection.

Note:

Table board double only possible in combinations armchair-couch and couch-couch.

Suspended shelf:

Choice of laminate (MFC) or HPL top with seamless, moisture-resistant laser edge (ABS edge). Suspension element steel plate. Metal surface powder-coated acc. to WH collection.

Perfect Partners.



nooi barstool



pulse conference chair



nooi conference chair

A-4950 Altheim
Linzer Strasse 22
T +43 (7723) 460-0
altheim@wiesner-hager.com

D-97080 Würzburg
Schürerstrasse 3
T +49 (931) 3 55 85-0
F +49 (931) 3 55 85 85
wuerzburg@wiesner-hager.com

NL-6101 XB Echt
Nobelweg 17
T +31 (475) 41 02 22
benelux@wiesner-hager.com

F-67201 Eckbolsheim
13, rue Ettore Bugatti
T +33 (3) 88 59 90 90
F +33 (3) 88 59 90 89
france@wiesner-hager.com

UK: Wiesner-Hager Ltd.
Fourth Floor
104-110 Goswell Road
London
EC1V 7DH
T +44 (20) 7490 3627
london@wiesner-hager.com

CZ-150 00 Praha 5
Drtinova 557/10
T +420 271 730 444
praha@wiesner-hager.com

Certified acc. to:
ISO 9001, ISO 14001
and ISO 14025