

IRYS

CLESTRA
Hauserman

BRINGING PEOPLE + IDEAS TOGETHER



reddot award 2016
winner

CLESTRA
Hauserman

BRINGING PEOPLE + IDEAS TOGETHER

For over a hundred years, Clestra Hauserman has manufactured and installed movable partitions. Ever since the dawn of the skyscraper in the early Modernist era, the company's expertise has complemented the evolution of the work space, offering cutting-edge technologies that have been inspired by the prevailing theories of work. With the IRYS system this process continues...



IRYS ADAPTS, EXPANDS AND CONTRACTS TO REFLECT YOUR ORGANISATION

THE IRYS SYSTEM

A NEW WAY TO EXPERIENCE SPACE

The result of two years' collaboration between HOK Product Design and Clestra Hauserman, the IRYS System has been designed to adapt easily to changes in office space.

Clestra Hauserman installed movable partitions in the first skyscrapers at the turn of the 20th century. Since then, the company has complemented developments in work space to offer the best possible technology inspired by on-going workplace theories.

Today's working practices can be individual, collaborative, remote and connected. Everything depends on the situation. But as objectives and requirements evolve, so facilities need to adapt accordingly.

IRYS meets the demands of modern organisations: it offers an infinite range of possibilities with solutions that can either be insular or promote sharing, meeting and thinking.

We are all different. Acknowledging and catering for these differences can go a long way to create harmony in the work environment.

IRYS is designed to promote cooperation in open-plan offices. It offers individuals an opportunity to be part of an enjoyable space that is conducive to their well-being and to increased productivity. IRYS can encourage creativity. It can evolve into totally new configurations that are inspired by your needs and aspirations.

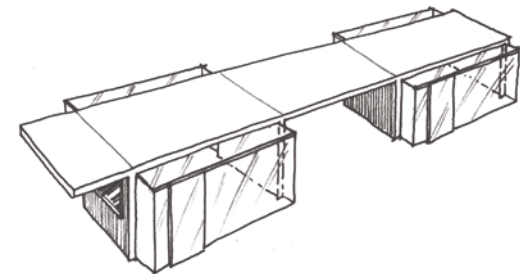
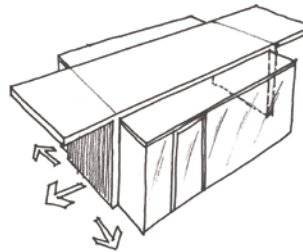
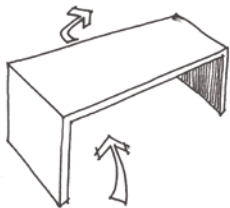



SIMPLIFY MEETINGS
PROMOTE CREATIVITY
REFRESH MINDS

SPACE FOR SOCIALISING

THE BRIDGE IS AN ELEMENTAL STRUCTURE, AN IMPLIED SPACE, WHICH DRAWS PEOPLE TOGETHER, THEREBY PROMOTING SOCIAL INTERACTION.

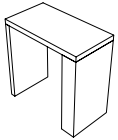

Bridge 2600 x 1400 mm

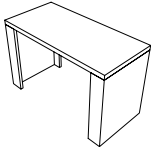

Bridge 4200 x 2000 mm

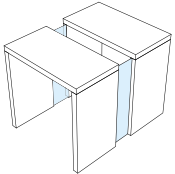

Double Bridge 2600 x 3400 mm

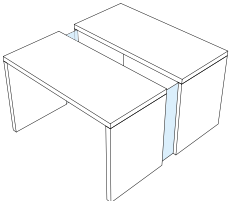

Double Bridge 4200 x 4600 mm

As the backbone of IRYS, the Bridge allows cross collaboration and informal interaction – both are sources of openness and comfort, fostering performance and productivity for the company. The Bridge is the solution. It facilitates meetings, creates connections and encourages teamwork

in a space that is totally open to its surrounding environment. Employees can make of it whatever they like – a discrete spot for a break, an informal venue for meeting a partner, an ideal location for an impromptu meeting.



IRYS 3600 x 3200 mm

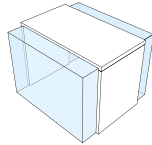

IRYS 4200 x 6400 mm

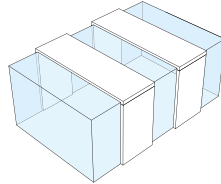

Double IRYS 7050 x 3800 mm

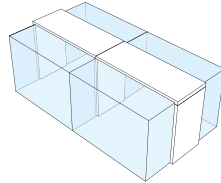

Triple IRYS 10 500 x 3800 mm

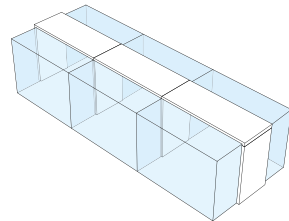

WORK SPACE

A PRODUCTIVITY HUB INSPIRED BY CONTEMPORARY THINKING

IRYS is born out of the need to provide structure to the working day. But needs change with priorities, and workspace has to respond.

IRYS offers users flexibility, comfort and intelligence to make their daily lives easier.

IRYS allows for heads down concentrative work as an individual or a team, higher efficiency and great insight.

THINK ALONE OR IN A GROUP
HOST A BUSINESS PARTNER
WRITE A REPORT
OR MAKE PHONE CALLS



LIVING SPACE

LIVE THE SCENARIOS THAT SUIT YOU

IRYS is completely flexible, it offers implied space as well as actual space; a hive of activity in tune with its environment; a crossroads where people meet to have a discussion. Whether they stop by a whiteboard or a Clestra MediaWall, they will share ideas and make progress.

Meetings can take place directly outside the enclosed IRYS or one can enter the IRYS to continue their conversation in privacy, taking advantage of every moment to succeed through discussion. Opportunities are generated when minds come together in a congenial environment.

SHARE TIME TOGETHER
ENCOURAGE DISCUSSION
SEIZE OPPORTUNITIES



Lounge



Bistro



Office / Meeting



25

45°

Candy 3



EVOLVING WORK SPACE

FOREVER CHANGING, JUST LIKE YOUR ORGANISATION

IRYS is like your organisation – multi-faceted and in motion. It is whatever you want it to be.

The module is based on a Bridge but you can choose and develop its configuration as required. Dimensions, equipment, walls, lighting, connections – everything can be customised and replaced. Connect the Bridges and finish them to your taste. Create a space for meeting and sharing that reflects the spirit of your organisation.

IRYS can be installed or moved in a day, as often as you want.

Since IRYS modules are not connected to the structure of the building, they are easy to install, alter and relocate. There is no floor or ceiling to replace and lighting is integrated, all that is needed is the outline of the new footprint. The costs of installation and use have a low impact on budget.



OPTIMISE YOUR COSTS
MAKE SPACE MORE FLEXIBLE

FACILITATE AND SIMPLIFY
FACILITIES MANAGEMENT



LIVE WALL

IRYS IS WHAT YOU WANT IT TO BE

The interior and exterior vertical surfaces of IRYS can be selected to meet with employee requirements. You simply identify the functions you require, whether acoustic, pin-board, magnetic, write-on or the interactive Clestra MediaWall. With nine different finishes and four options, you set the scene for your IRYS.

Once you have defined your own requirements, you can let your imagination run wild. So instead of putting up with fixed facilities, you can select a series of changeable settings.

ALL SURFACES ARE
FUNCTIONAL



9 FINISHES

4 OPTIONS





steel, wood, fabric, glass, micro-perforated steel or wood, whiteboard, soundproof wall covering, or Clestra MediaWall.

shelves, storage cabinets, occasional desk, or flat screen.

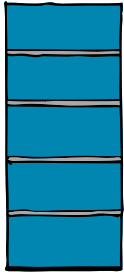
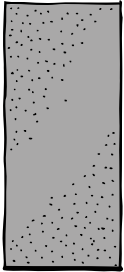
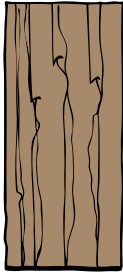
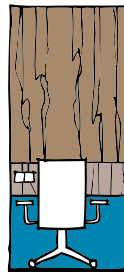

AN INFINITE NUMBER OF COMBINATIONS

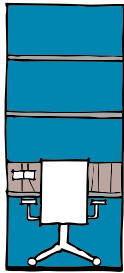
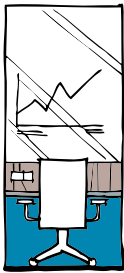
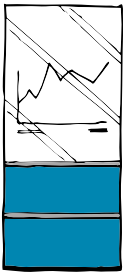
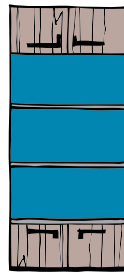
Examples of different possible combinations

 <p>Shelves</p>	 <p>Steel acoustic panel</p>	 <p>Wood</p>	 <p>Occasional desk</p>	 <p>Flat screen</p>	 <p>Flat screen 2 storage cabinets</p>
 <p>2 shelves 1 occasional desk</p>	 <p>Whiteboard 1 occasional desk</p>	 <p>Whiteboard 2 shelves</p>	 <p>2 storage cabinets 2 shelves</p>	 <p>Flat screen 2 shelves 1 storage cabinet</p>	 <p>Flat screen 3 shelves</p>

CLESTRA
Hauserman

BRINGING PEOPLE + IDEAS TOGETHER





A MULTIMEDIA AND COLLABORATIVE SOLUTION

CLESTRA MEDIAWALL

Clestra MediaWall is a multimedia work surface connected to the Internet to encourage collaborative working. Clestra MediaWall can be customised according to the company's requirements. It is totally open, promoting both local and remote communication.



CLESTRA MediaWall



USB port



Technical panel

INTEGRATED TECHNOLOGY

ROOM-BOOKING

When you require space for a meeting, the IRYS room-booking function makes life easier. It allows you to manage bookings efficiently using its interactive interface connected directly to your management software.



Room booking

SWITCHABLE GLASS

Transparency is a common feature of the modern office, but it can limit the use of space and be inappropriate when discreet settings are required. Solve this problem with switchable glass technology: at the touch of a button, a transparent, glazed IRYS partition becomes opaque to allow private working. And by just touching the glass, transparency is restored – instantly.



“Switchable” glass, OFF position
with film on the sliding door



“Switchable” glass, ON position
with film on the sliding door



A glass-walled meeting room with a blue wall and a white table. A large digital display is mounted on a wooden structure, showing a presentation. The display content includes:

- Collaboration
- The solution
- Partnership of kind
- Process
- Outcomes

Two yellow chairs and a white coffee table. The coffee table has a glass of water on it.

LIGHTING AMBIENCE

ABSORBENT TENSIONED FABRIC

Absorbent tensioned fabric with integral LED technology provides uniform lighting over the entire area of your work space - with no 'hot' spots. The result is a contemporary, ambient lighting effect that can increase concentration, stimulate creativity and enhance performance.

Select your desired lighting level using the dimmable system ranging from 0 to 1,000 Lux. Alternatively, choose from a selection of pre-set options designed to provide optimal lighting for various work space applications.

ACOUSTIC PERFORMANCE

Tensioned fabric with built-in lighting improves the coefficient of sound absorption, thereby providing optimal comfort.

METAL CEILING

IRYS can be supplied with a perforated metal ceiling, specifically designed for optimal sound absorption. Metal ceilings are made to measure to customers' technical specifications, making it possible to incorporate a customised lighting system.

CANOPY

The canopy juts out, delineating a space. Canopies emphasise structure and space, as well as creating a welcoming ambiance.



Metal ceiling with integrated lighting



Canopy with integrated absorbent tensioned fabric

OPENINGS

DISCOVER THE DOOR STYLE THAT FITS YOUR NEEDS

Whether hinged or sliding, each door option fits perfectly into the overall IRYS configuration. For acoustic performance, choose the glass door with frame and retractable bottom door seal. For a more minimalist effect, choose the frameless door with integrated hinges and door closer.

The sliding door and its ingenious mechanism integrated inside the upright allow the optimisation of space within IRYS. Equipped with a soft closer, the sliding door ensures a smooth and silent operation.

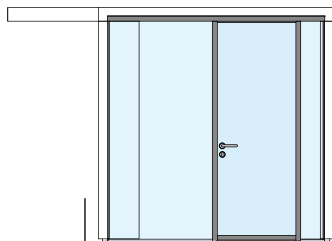

Glazed door with frame

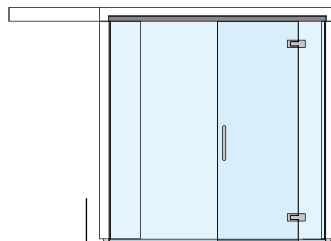

Glazed door without frame

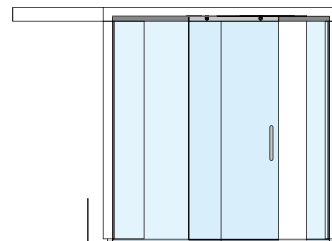

Glazed sliding door



ARCHITECTURAL DETAILS

SLEEK DESIGN

Design can have a tremendous effect on behaviour in the work place. Harmonious proportions and the judicious combination of materials can relax and reassure. The sleek design of IRYS does not constrain but instead promotes creative thinking by incorporating a screen onto which people can project their own ideas.

We have designed IRYS to be aesthetically pleasing so that not only can you inspire your employees but also make the most of available space. The attention we have given to detail ensures trouble-free assembly. Everything is built-in and cleverly concealed so that all that is visible is the perfection of the finish.



1. Junction between glass partition and wood cladding of the Bridge



2. Junction of canopy and MediaWall



3. Top junction between glass and upper rail (incorporating cable conduit)



4. Junction of glass at Bridge structure showing the recessed detail

ACOUSTIC PERFORMANCE

Acoustic comfort may be a challenge for new work spaces, but it is a priority for IRYS. Thanks to its design and the innovative materials used, IRYS cuts out external noise and absorbs internal resonance to provide optimal acoustic performance.

ACOUSTIC ABSORPTION

The measured reverberation time inside an IRYS module exceeds the requirements of the NFS31080 standard.

SOUND INSULATION

Depending on the materials selected, acoustic performance can be improved further. The value achieved is:

DNT, A = up to 35 dB

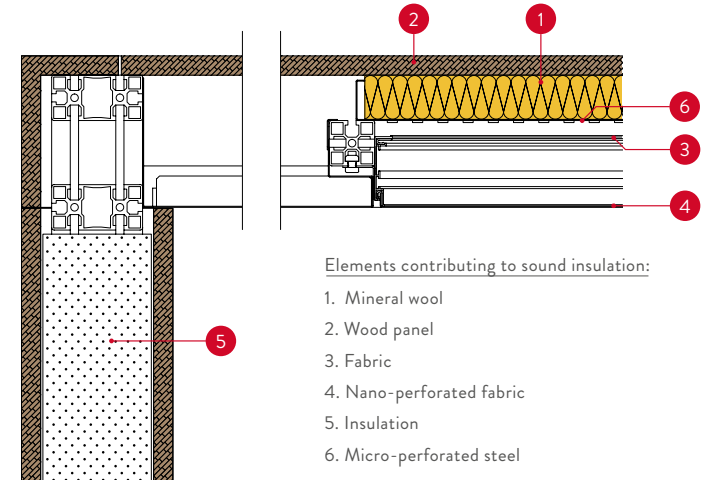

Elements contributing to sound insulation:

1. Mineral wool
2. Wood panel
3. Fabric
4. Nano-perforated fabric
5. Insulation
6. Micro-perforated steel

Reverberation inside the IRYS module⁽¹⁾

(interrupted source; results rounded to nearest 0.05 sec.):

Octave band	125	250	500	1000
Tr ⁽²⁾ in second	0,50	0,35	0,35	0,30
Octave band	2000	4000	8000	Tr 500-1K-2K
Tr ⁽²⁾ in second	0,30	0,30	0,30	0,30

Objectives according to NFS31-080:

Values for reverberation time (Tr ⁽²⁾ 500-1k-2kHz) in seconds, applicable to unoccupied furnished premises		
Type of premises	“Efficient” performance	“Highly efficient” performance
Individual offices	Tr ≤ 0,7	Tr ≤ 0,6 ⁽³⁾
Group offices (at least 2 workstations)	Tr ≤ 0,6	Tr ≤ 0,5 ⁽³⁾
Meeting rooms / training classrooms (volume < 250 m ³)	0,6 ≤ Tr ≤ 0,8	0,4 ≤ Tr ≤ 0,6 ⁽³⁾

(1) The values achieved correspond to a configuration with acoustic single glazing, swing door with door frame, Live wall with micro-perforated steel (IRYS module dimensions: 2600 x 2600 mm - height: 2450 mm).

(2) Tr (reverberation time): Reverberation time indicates the speed of extinction of a sound once it stops being emitted.

(3) The values achieved by IRYS are at the “highly efficient” level of performance.

AIR RECYCLING

A HEALTHY ENVIRONMENT

Clestra Hauserman has joined forces with a global engineering design firm to make IRYS a healthy work space.

The air inside an IRYS module is renewed constantly. For user comfort, a silent ventilation system designed to meet the most stringent European standards makes it possible to renew 40 m³ of air per hour and per person.

IRYS 2600 x 2600 mm

Maximum air flow per hour: 250 m³

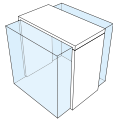

IRYS 4200 x 4400 mm

Maximum air flow per hour: 500 m³/h

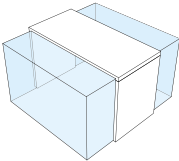

IRYS 4200 x 6400 mm

Maximum air flow per hour: 1000 m³/h

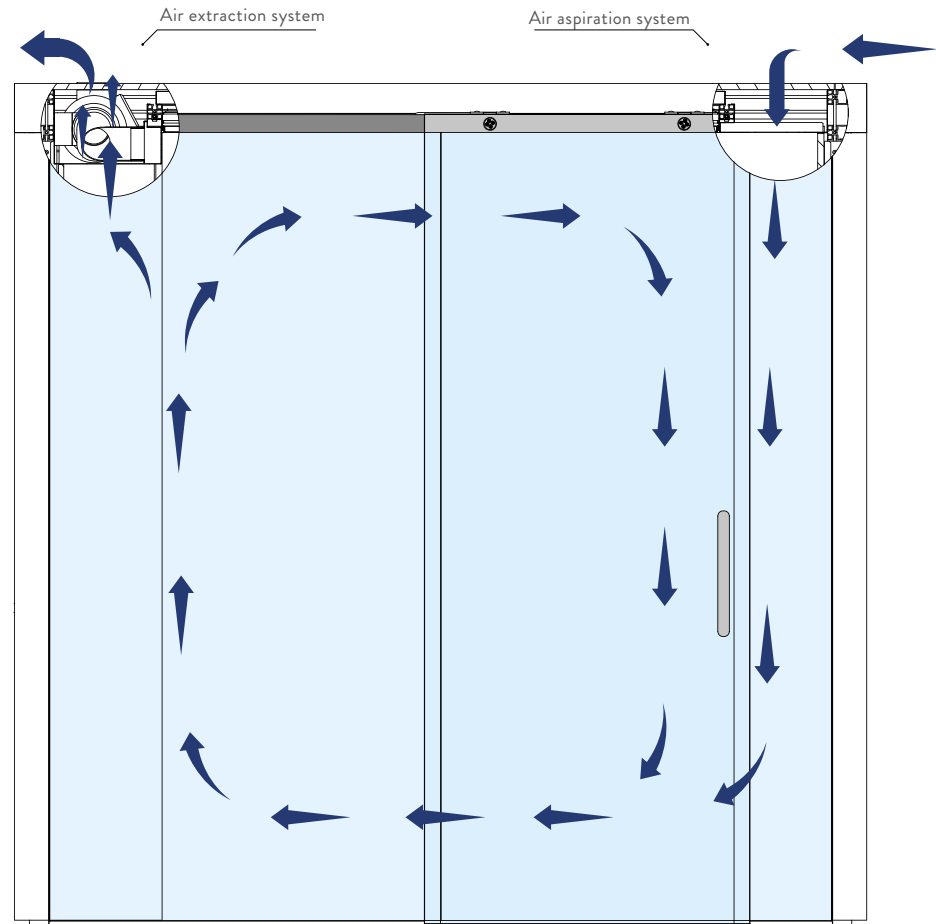
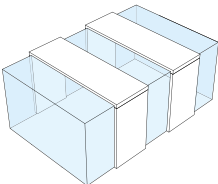

EASE OF INSTALLATION

AUTONOMY

IRYS is autonomous and self-supporting; and is also independent of the building's structural elements.

PLUG AND PLAY

Once installation is complete, IRYS is operational immediately.
All electrical wiring is incorporated at the factory.
All that is needed is for an authorised electrician to connect IRYS to the building's electricity supply.

FITTING TIME

Average assembly time:

IRYS:

2600 x 2600 mm, with canopy:
8 hours (2 people)

BRIDGE:

2600 x 1400 mm: 4 hours (2 people)



Lighting ambience



Air recycling



Access control



Audiovisual integration



Switches



Network integration



RESPECT FOR THE ENVIRONMENT

IRYS has been designed to minimise its impact on the environment.

ENVIRONMENT-FRIENDLY MATERIAL

Genuine wool felt, wood from sustainably managed forests, metal structure – all materials used in the manufacture of IRYS are recycled and/or are recyclable.

LONG LIFE

IRYS is not a disposable product: it is a product that can be relocated, transformed, enlarged, decorated and demounted according to requirements, preferences and changes in the configuration of spaces.

ZERO WASTE

IRYS is a 100% pre-fabricated system. As a result, its on-site assembly does not generate any waste.

Clestra Hauserman's factories are triple certified, to ISO 9001, ISO 14001 and OHSAS 18001; IRYS is manufactured in accordance with these standards.



CUSTOMISED FINISHES

CUSTOMISE IRYS TO SUIT YOUR STYLE OR CREATE THE ATMOSPHERE YOU DESIRE

IRYS can not only be designed with materials of your choosing, but the decor can be changed whenever necessary. Finishes have been carefully

selected for both their aesthetic appeal and their technical performance. They are complementary and mutually enriching.

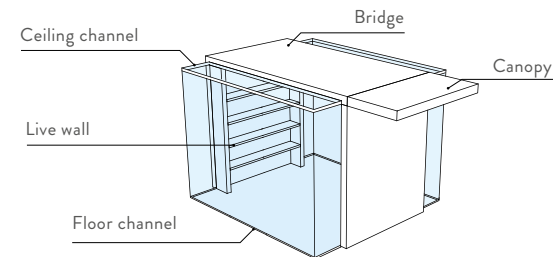

	1	2	3	4	5	6
Bridge and canopy		•	•	•		
Live wall	•	•	•	•	•	•
Ceiling and floor channels	•					

1
COLOUR-COATED
STEEL /
ALUMINIUM



2
SELF-
COLOURED
LAMINATES

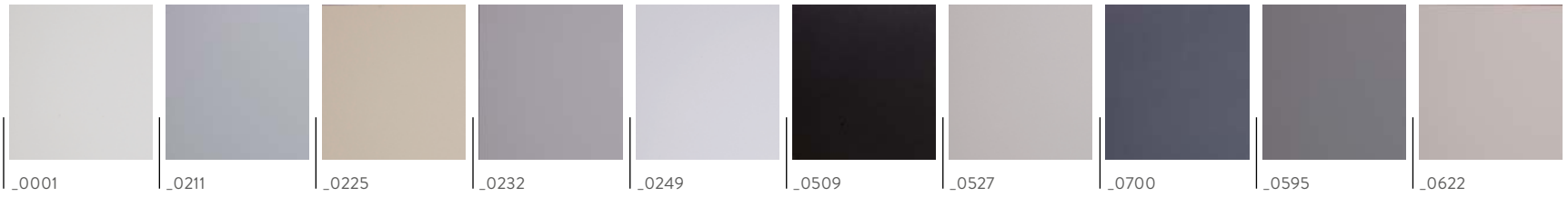

3
WOOD
LAMINATES

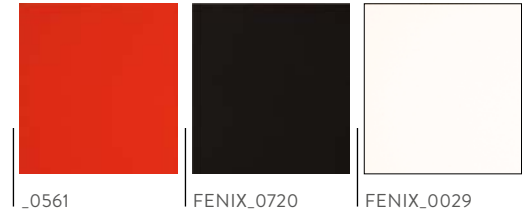

4
NATURAL
WOOD

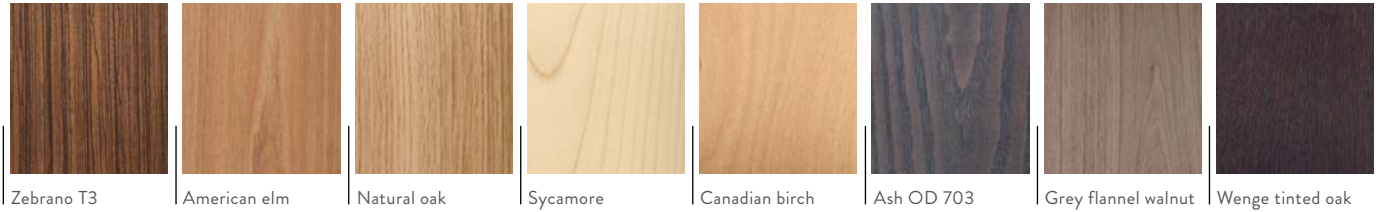

5
SYNTHETIC
FABRICS

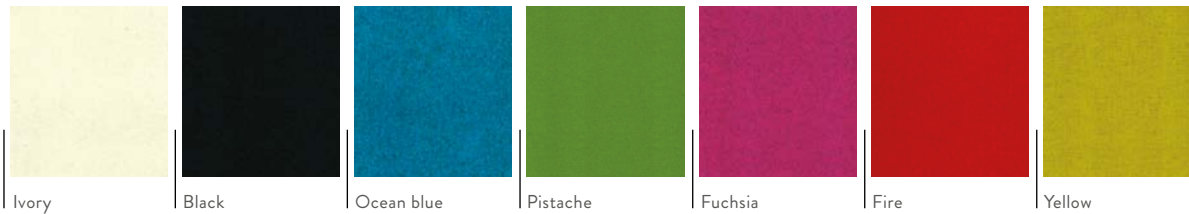

6
WOOLLEN
FABRICS

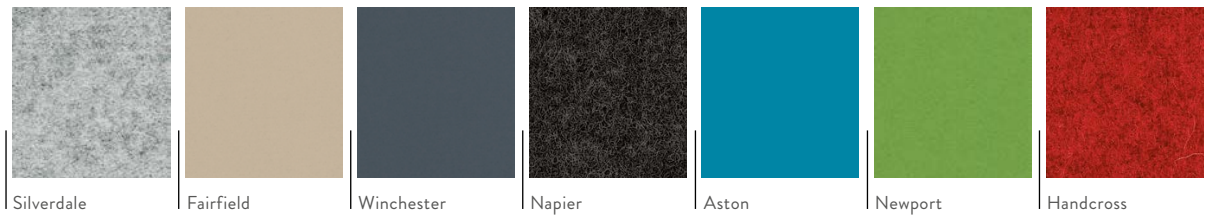

THE IRYS RANGE

BRIDGE

	Length (mm)	Width (mm)	Max. # of people
1	2600	1400	2
2	3600	1400	4
3	4200	1400	4
4	2600	2000	4
5	3600	2000	6
6	4200	2000	6

DOUBLE BRIDGE

	Length (mm)	Width (mm)	Max. # of people
7	2600	3400	4
8	3600	4000	8
9	4200	4600	12

EXTERNAL HEIGHT

The entire range is available in two heights: 2450 mm and 2600 mm.

IRYS

	Length (mm)	Width (mm)	Max. # of people
1	2600	2600	2
2	3600	3200	4
3	3600	3800	6
4	4200	4400	8
5	4200	6400	12
6	4200	7000	12

DOUBLE IRYS

	Length (mm)	Width (mm)	Max. # of people
7	5050	2600	4
8	7050	3800	12
9	8250	4400	16

TRIPLE IRYS

	Length (mm)	Width (mm)	Max. # of people
10	7500	2600	6
11	10500	3800	18

BRIDGE

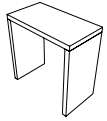

1

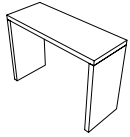

2

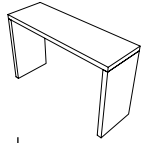

3

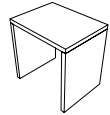

4

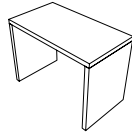

5

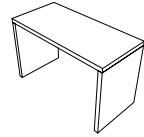

6

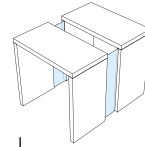

7

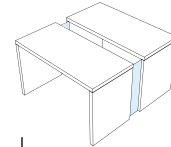

8

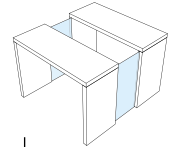

9

IRYS

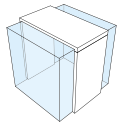

1

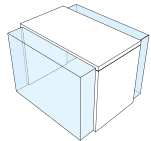

2

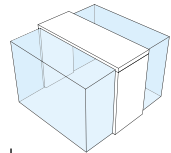

3

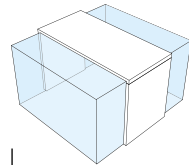

4

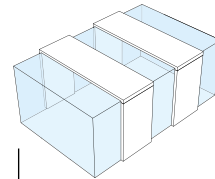

5

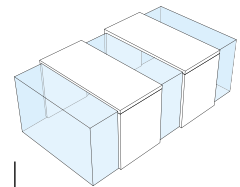

6

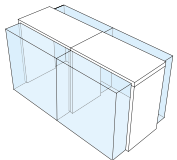

7

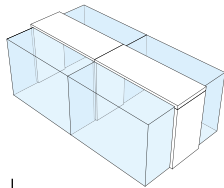

8

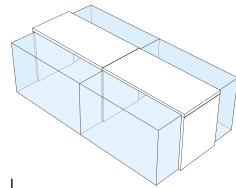

9

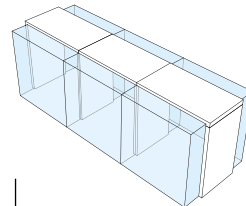

10

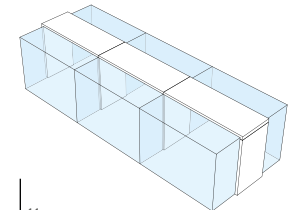

11

WWW.CLESTRA.COM

CLESTRA
Hauserman

BRINGING PEOPLE + IDEAS TOGETHER